



SSSD and FreeIPA

Advanced user management in Linux

Red Hat Czech s.r.o.
Jan Zelený
12th February 2011



Part 1:

LDAP and Kerberos

What options do we have?

Glossary recapitulation

- Identification
- Authentication
- Authorization
- Directory

Using advantages LDAP and Kerberos

- Server
 - LDAP database for KDC
 - FreeIPA, AD
- Client
 - pam_ldap, pam_krb5
 - nss_ldap
 - sssd



Part 2:

FreeIPA and SSSD

FreeIPA as an integrated server

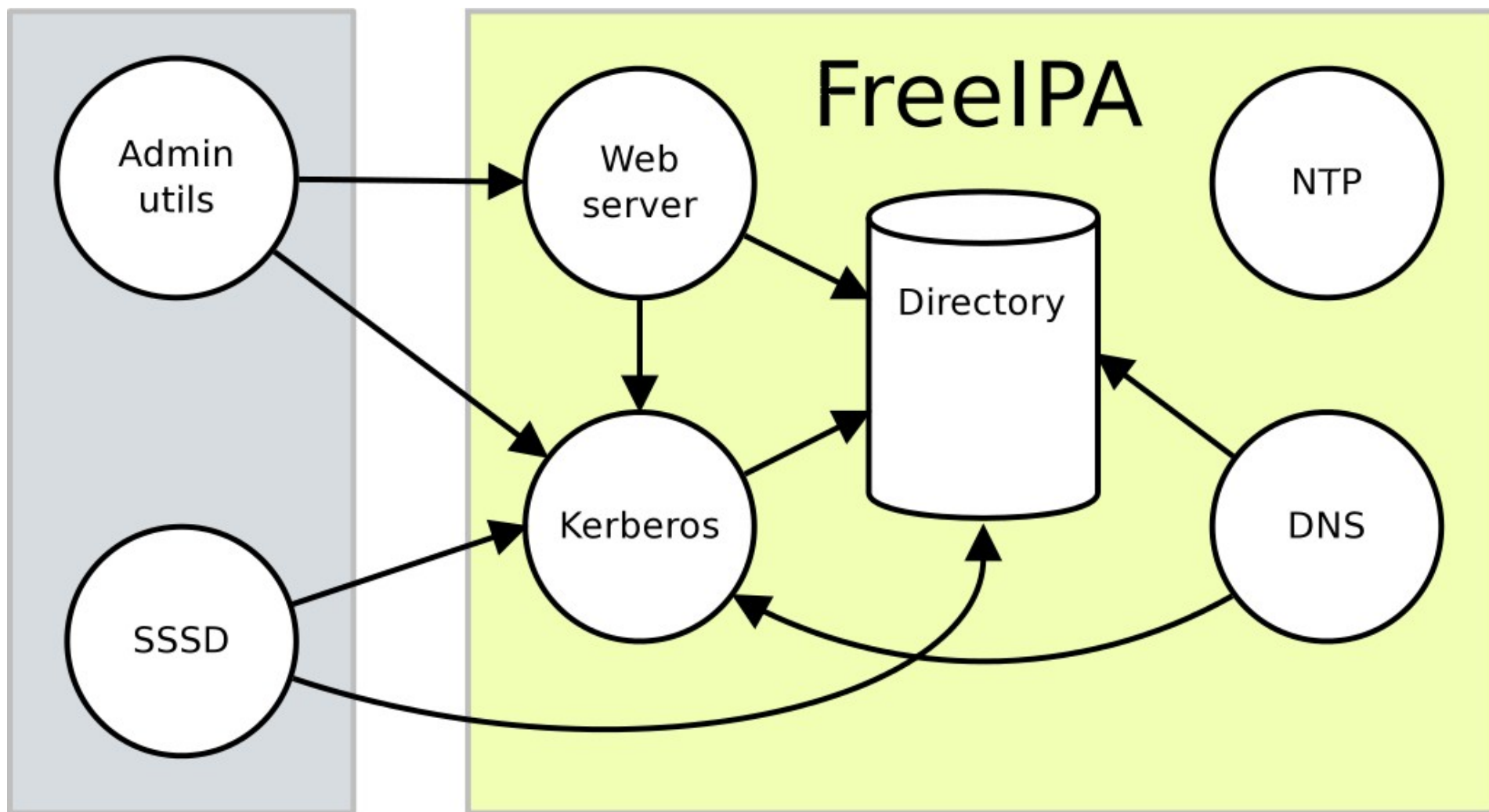

FreeIPA: advantages and possibilities

- Management of users and groups
- Management of hosts
- HBAC
- sudo with LDAP backend

SSSD as an integrated agent

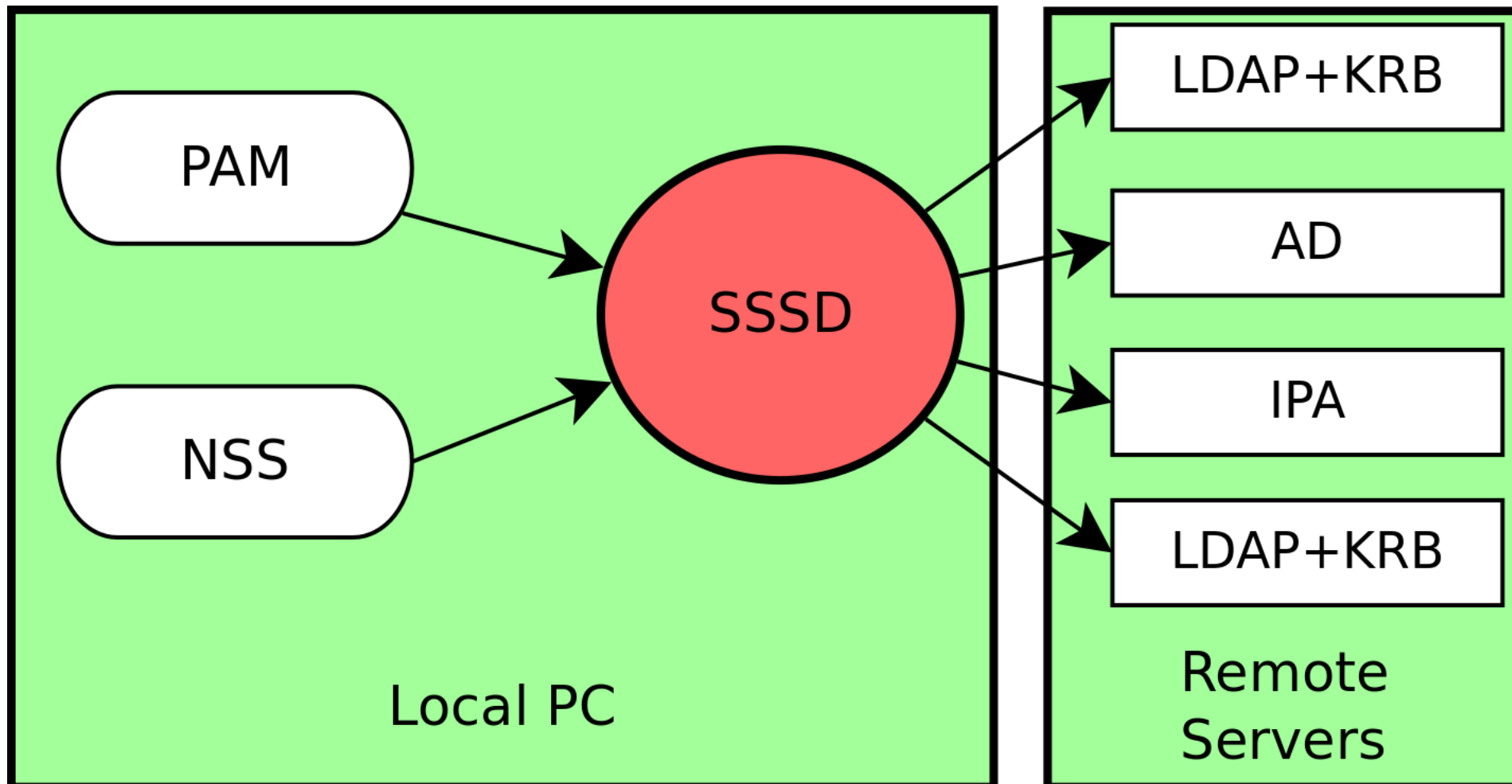

SSSD: advantages and possibilities

- Cache
- Single sign-on
- More domains at once, failover
- Online detection
- Integration with FreeIPA



Part 3:

Questions, lab invitation